

**SERIES 100 GENIE MEMBRANE SEPARATOR MODEL 101
INSTALLATION AND OPERATION INSTRUCTIONS**

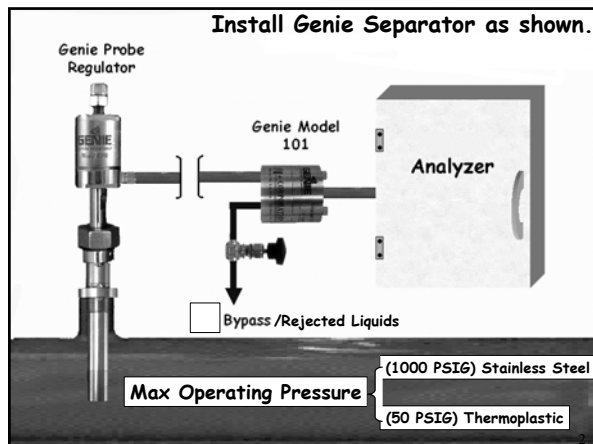

41041 Black Bayou Rd, Gonzales, Louisiana, USA 70737
Phone (225) 644-5255 FAX (225) 644-3975
www.geniefilters.com sales@geniefilters.com

03/24/03



Max operating temperature of a Genie Model 101

	Stainless Steel	Thermoplastic
W/Type 5 or BTU Membrane	85°c	85°c
W/Hi-Flow Membrane	150°c	100°c

Insure that the sample gas temperature down stream of the Genie is the same or higher than the temperature of the Genie Separator to prevent condensation of sample gas.

3

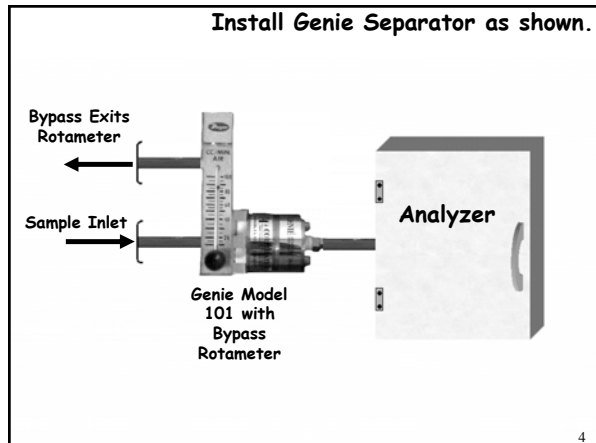

4

Establish the minimal "bypass" flow to bring fresh sample quickly and allow for continuous removal of separated liquids.

Avoid "blowing down" sample from Genie's "bypass" port that may allow the "inlet" pressure to drop below the "outlet" pressure resulting in reverse flow.

5

To protect the membrane from physical damage should re-verse flow occur, install a Membrane Retention Plate (MRP)

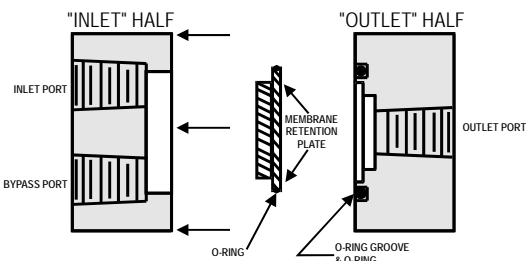

6

Maintain the lowest possible "inlet" port sample pressure consistent with good overall system operation. It is important to note that sample flow will cease should liquid fill the entire "inlet" portion of the Genie housing. Most system designs would then allow the sample pressure downstream of the Genie Separator to "bleed off" to zero. With the downstream pressure at zero, the membrane differential pressure is now equal to the sample pressure supplied to the Genie's "inlet" port. If the membrane differential pressure is excessive at the same time that the "inlet" is flooded with liquid, it is possible that small quantities of liquid may be forced through the membrane. Back-pressure control of sample gas downstream of the Genie Separator would eliminate this problem. Therefore, it may be desirable to provide back-pressure control on the Genie's "outlet" gas stream if either of the two following conditions prevail: SEE NEXT FRAME →

7

-The Genie Separator's "inlet" pressure exceeds 10 PSIG and liquid hydrocarbon is likely to fill the "inlet" portion of the housing.

-The Genie Separator's "inlet" pressure exceeds 30 PSIG and water or other liquids exhibiting high surface tension characteristics are likely to fill the "inlet" portion of the housing

8

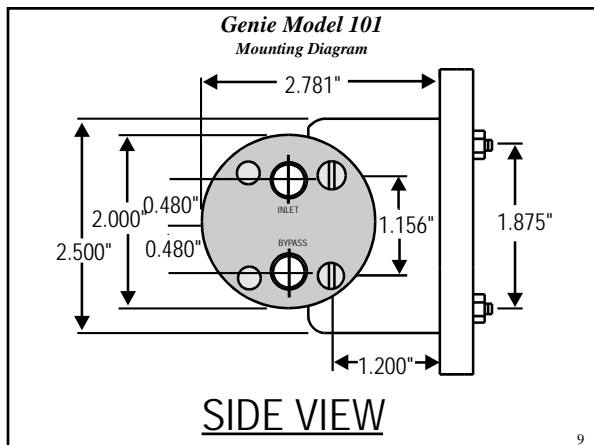

9

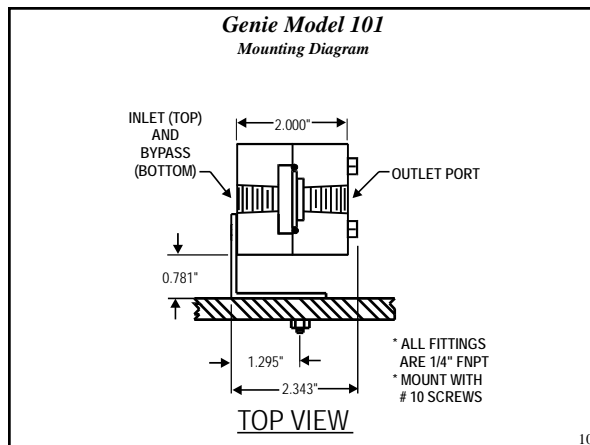

10

Type 5 membrane

For customers currently using our Standard (red or green) Membrane, we strongly recommend upgrading to the New Type 5 Membrane. Genie Membrane Separators currently in service can easily be upgraded by purchasing a Type 5 Membrane Replacement Kit. The new membrane is available for use in all Series 100 Genie Membrane Separators.

Benefits of using the new membranes are:

- Improved liquid hydrocarbon rejection capabilities
- 15 times greater flow rate capacity than the Standard (red or green) Membrane
- Greater life expectancy for membrane

11

TYPICAL APPLICATIONS

Protection against liquids for gas chromatographs, mass spectrometers, oxygen analyzers, moisture analyzers, and other analyzers with low sample flow requirements.

SPECIFICATIONS

Maximum operating pressure

Stainless Steel	1000 PSIG
Polypropylene	50 PSIG
Kynar	50 PSIG

Internal volume - Genie Membrane Separator

Housing inlet	0.30 cubic inches
Housing outlet	0.09cubic inches

12

Maximum operating temperature of Genie 101		
	Stainless Steel	Thermoplastic
With Type 5/BTU membrane	85°C	85°C
With Hi-Flow membrane	150°C	100°C
Ports (inlet, bypass, outlet)	14" Female NPT	
Typical membrane pressure drop		
With Type 5/BTU membrane	1 PSI per 720cc/min. of gas flow through the membrane	
With Hi-Flow membrane	1 PSI per 4000cc/min. (4 liters/min.) of gas flow through the membrane	
O-Ring	Viton (standard) other elastomer materials available	

13

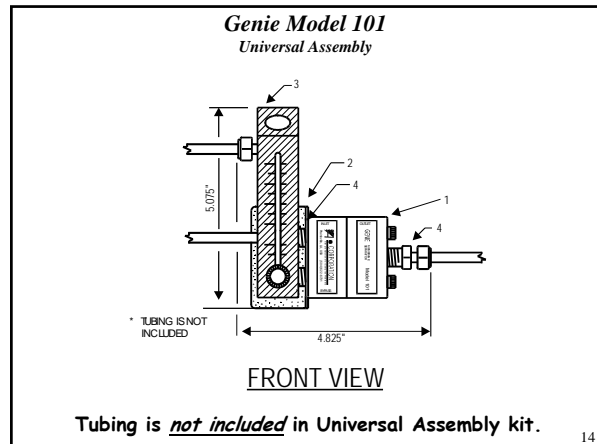

14

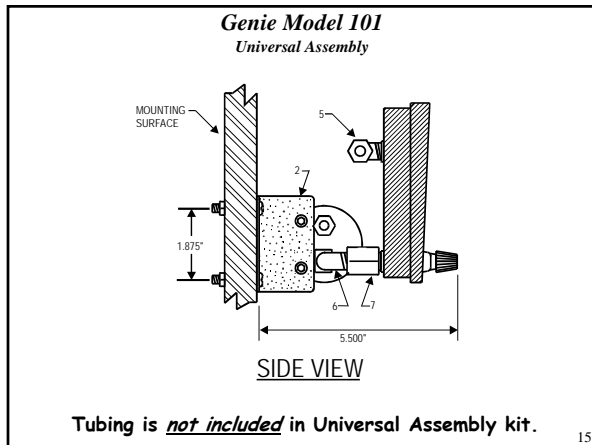

15

- The following items are included in the Model 101
Universal Assembly:**
- 1) Genie Model 101 - Genie Model 101 equipped with a new Type 5 or Type 6 (BTU) Membrane and Membrane Retention Plate
 - 2) Stainless Steel Mounting Bracket- (A+ Corporation part # 101-509-SS)
 - 3) Bypass Rotameter - (10-100 cc/min. part # 101-RMA-150-SSV) with integral valve
 - 4) Male Connector- (1/4" male pipe to 1/8" tube, 2 each, part # 101-SS-200-1-4)
 - 5) Male Elbow- (1/8" male pipe to 1/8" tube, part # 101-SS-200-2-2)
 - 6) Male Elbow-(1/4" male NPT to 1/4" male NPT, part # 101-SS-4-ME)
 - 7) Reducing Adapter- (1/4" female NPT to 1/8" male NPT, part # 101-SS-4-RA-2)
 - 8) Membrane Retention Plate- (Not shown - fits internally in Genie, part # 101-MRP)

16

**Membrane Replacement Kit Part # 101-5x5 -
Type 5 Membrane Kit (5 spare membrane and 1 O-ring)**

**Membrane Replacement Kit Part # 101-5x6 -
BTU Membrane Kit (5 spare membrane and 1 O-ring)**

**Membrane Replacement Kit Part # 101-5x2 -
Hi-Flow Membrane Kit (5 membrane/O-ring assemblies)**

The "x" indicates the O-ring elastomer type: 0 = Viton,
1 = Kalrez,
2 = EPDM,
3 = Buna N.

17

**SEE OUR WEBSITE FOR OTHER PRODUCTS & LITERATURE
AVAILABLE FROM A+ CORPORATION**

www.geniefilters.com

Moisture and Corrosion Control Products - Request Brochure B-MCC

Natural Gas Industry Products (including 410 & Glysoorb) - Request Brochure B-NGI

Analyzer Application Notes - Consult A+ Corporation technical support for specific applications

Series 100 (Gas/Liquid) Genie Membrane Separators - Request Brochure B-100

Series 200 (Liquid/Liquid) Genie Membrane Separators - Request Brochure B-200

Diaphragm Sample Pump - Request Application Note and Installation Instructions

140 Series Membrane Separator Probes (Ambient Air Monitoring Filters) - Request Brochures B-142 and B-143

18