



Tornado Model 602

Installation & Operation Instructions



Installation

Mount the Tornado vertically as shown in Figure 1. Note that the “bypass” port is located at the center-bottom of the body to prevent liquid accumulation. The “inlet”, “outlet”, and “bypass” 1/2” NPT ports are conveniently located on the stationary body 90° apart for easy tubing runs. Therefore, it will not be necessary to disconnect the sample lines to replace filter elements. The four cover bolts have been torqued to 50 ft-lbs at the factory. After the bolts have been loosened or removed, they must be torqued to 50 ft-lbs (or wrench-tight if a torque wrench is not available) to insure proper sealing of the cover. The Teflon gasket must be replaced each time the cover is removed from the body.

Figure 1 - Mounting Diagrams & Port Locations

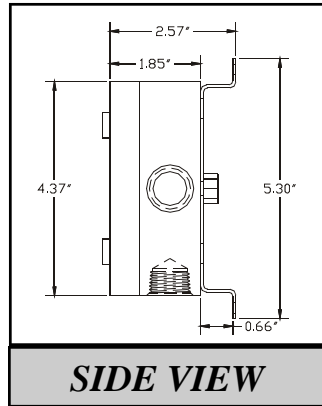
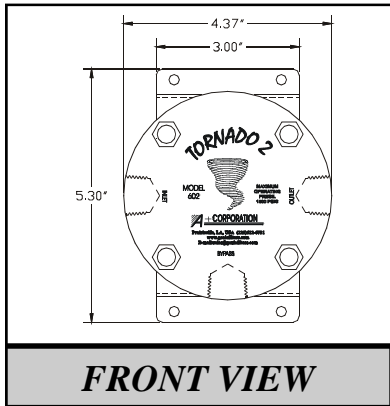

NOTES:
 Mount bracket to surface with #10 screws
 All ports are 1/2” NPT
 Maximum operating pressure 1500 PSIG (at ambient temperature)

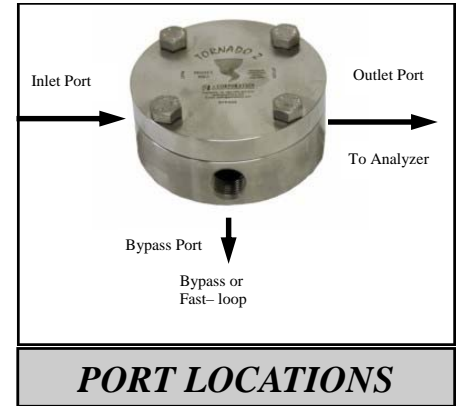

The Tornado Model 602 may be utilized to remove micron and sub-micron particles from liquid samples. Once flow has begun, establish a “bypass” flow to bring fresh sample to the filter quickly and to provide the self-cleaning action.

Choose the appropriate element based on the micron size of the particles to be removed. Particulate will be swept away from the element’s surface by self-cleaning tornadic action.

PART ORDERING INFORMATION

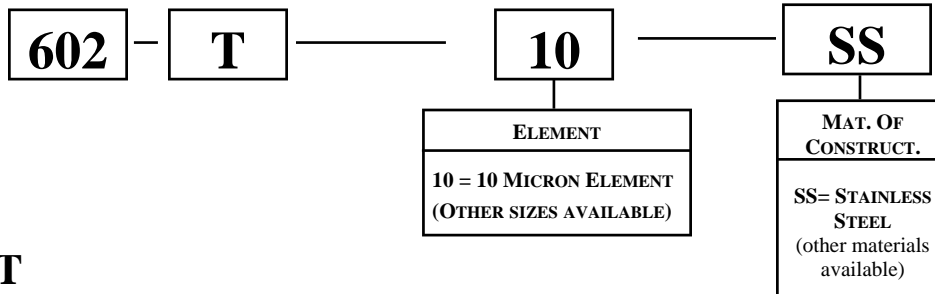

BRACKET KIT

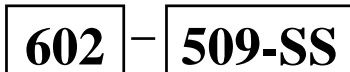

Teflon® is a registered trademark of the Dupont Corporation



41041 Black Bayou Rd, Gonzales, Louisiana, USA 70737
 Phone (225) 644-5255 FAX (225) 644-3975
www.geniefilters.com sales@geniefilters.com